



# Multi-Max® FA-3

ROOF

WALL

SPECIALTY

## Insulation for Above the Deck

### Doing one thing well in so many ways...

Rmax is a U.S. owned company that only manufactures polyiso insulation. Multi-Max FA-3 is manufactured in the U.S. and is offered through an extensive distribution network. It is available in standard four foot wide panels, with standard panel lengths of four or eight feet. Custom lengths are available for special orders. Contact Rmax Sales at your regional Customer Service Center for product availability, pricing information, and your nearest distribution center.

#### Corporate & Technical

Rmax Operating, LLC  
13524 Welch Road  
Dallas, Texas 75244-5291  
Phone: (972) 387-4500  
Fax: (972) 387-4673  
Email: [rmax@rmax.com](mailto:rmax@rmax.com)  
Web: [www.rmax.com](http://www.rmax.com)

#### Customer Service & Plant Locations

##### Central Region

Dallas, Texas  
(800) 527-0890 Ext. 102

##### Eastern Region

Greer, South Carolina  
(800) 845-4455 Ext. 156

##### Western Region

Fernley, Nevada  
(800) 762-9462 Ext. 156

### PRODUCT DESCRIPTION

Rmax Multi-Max FA-3 is an energy-efficient thermal insulation board composed of a closed-cell polyisocyanurate (polyiso) foam core bonded to glass fiber/organic mat facers on both sides. Multi-Max FA-3 utilizes a CFC-, HCFC- and HFC-free blowing agent that has zero Ozone Depletion Potential (ODP) and negligible Global Warming Potential (GWP). This insulation is suitable for use in insulated roofing system constructions utilizing built-up roof (BUR), modified bitumen or single ply membranes and metal panel roofing systems. Multi-Max FA-3 is approved for use in new roofing constructions and limited retrofit/recover roofing constructions over steel, wood, non-combustible and certain types of nailable roof decks.



### CONSTRUCTION APPLICATIONS

- Built-up roof
- Modified bitumen
- Fully adhered single ply
- Mechanically attached single ply
- Loose laid ballasted single ply
- Metal panel roofing

### INCENTIVE OPPORTUNITIES

- Reduces energy costs
- Reduces material and labor costs
- Contributes toward LEED® credits
- Offers tax credits, where applicable

### COMPLIANCES

- ASTM C1289 Type II, Class 1
- International Building Code (ICC) Chapter 26 Section 2603, Foam Plastic
- ASHRAE 90.1
- NOA No. 09-0303.03, Miami-Dade County, Florida, Expires July 5, 2011
- RR 25378, City of Los Angeles Research Report
- California Code of Regulations, Title 24
- Factory Mutual – Class 1 roofing insulation per FM Standard 4450 (1.5" minimum thickness). Multi-Max FA-3 is subject to the conditions of approval as a roof insulation when installed as described in the current edition of the FMRC "Approval Guide". Refer to FM Approvals RoofNav for specific system details.
- Underwriters Laboratories – UL listed and labeled as shown in UL Certifications Directory:
  - Class A for External Flame – UL Standard 790
  - Class A for Internal Flame – UL Standard 1256
  - Fire Rated Roof/Ceiling Assemblies – UL Standard 263

### THERMAL PROPERTIES / PRODUCT DATA

"R" means resistance to heat flow. The higher the R-value, the greater the insulating power.

Nominal Thickness <sup>1</sup> Inches	Long Term Thermal Resistance (LTTR) <sup>2</sup>	Bundle Data <sup>3</sup> (48" x 96")		Truckload Data (48" x 96")	
		Pieces	Sq. Ft.	Pieces	Sq. Ft.
1.50	9.0	32	1,024	768	24,576
2.00	12.1	24	768	576	18,432
2.50	15.3	19	608	456	14,592
3.00	18.5	16	512	384	12,288
3.50	21.7	13	416	312	9,984
4.00	25.0	12	384	288	9,216

<sup>1</sup>The 1.50 inches and thicker products are approved for FM Class 1-90 wind uplift.

<sup>2</sup>LTTR values are determined in accordance with CAN/ULC-S770. LTTR predicts a 15-year, time-weighted average.

<sup>3</sup>Multi-Max FA-3 is shipped in bundles that are approximately 48 inches high and wrapped in plastic for easy handling.

NOTE: Metal deck flute span shall be a maximum of 4 3/8".

Visit [www.rmax.com/resources.asp](http://www.rmax.com/resources.asp) for a complete list of thicknesses and packaging information.



**TYPICAL PHYSICAL PROPERTIES**

Physical properties shown are based on data obtained under controlled conditions and are subject to normal manufacturing tolerances.

Property	Test Method	Results
Density, Overall, Nominal	ASTM D1622	2.0 pcf
Compressive Strength	ASTM D1621	20 psi <sup>1</sup>
Flame Spread, Core <sup>2</sup>	ASTM E84	25 - 60
Smoke Developed, Core <sup>2</sup>	ASTM E84	75 - 160
Water Vapor Transmission	ASTM E96	< 1.5 perm
Water Absorption	ASTM C209	< 1% Vol.
Dimensional Stability	ASTM D2126, 7 days, 158°F, 98% rh	< 2% Linear Change
Service Temperatures		-40°F to +250°F

<sup>1</sup>Also available in Grade 2 or Grade 3 upon request.

<sup>2</sup>Flame Spread and Smoke Developed Indexes are used to measure and describe the properties of this material in response to heat and flame under controlled laboratory conditions and should not be used to describe or appraise the fire hazard or fire risk of this material and other related roofing components under actual fire conditions.

**APPLICATION / INSTALLATION**

**General** - Multi-Max FA-3 is applied to the roof deck in order to provide a continuous layer of thermal insulation and a suitable substrate for the application of many different kinds of roofing membranes available in the market today.

Multi-Max FA-3 must be secured to steel or wood roof decks with FM listed mechanical screw and plate fasteners. It may be secured to other types of "nailable" decks with suitable mechanical fasteners for that type of "nailable" deck. Multi-Max FA-3 shall be adhered to properly prepared concrete roof decks with hot bitumens or air-cured polyurethane foam adhesives. For applications utilizing hot bitumens, the asphalt should be applied at its recommended equiviscous temperature (EVT) plus or minus 25°F. Adhesives shall be used in strict accordance with recommended installation procedures as supplied by the manufacturer.

**NOTE: Panel size shall be limited to 4'x 4' when hot bitumens are used or when the insulation is being installed over concrete decks.** No more insulation shall be laid than can be covered with the completed membrane system by the end of the day's work. Refer to PIMA Technical Bulletin 109 for storage and handling recommendations.

Rmax strongly recommends that the decision to use or not use a vapor retarder in any insulated roofing assembly be guided by the recommendations of the National Roofing Contractors Association (NRCA) in the latest edition of the "NRCA Roofing and Waterproofing Manual".

Designers and installers are referred to Rmax publication "General Notes for Use of Rmax Roofing Insulations in Low Slope Applications," for specifics regarding construction applications utilizing Rmax roof insulation products.

**Multi-Layer Insulation Systems** - The roofing industry has long recognized the advantages of multi-layered insulation systems; e.g. the reduction of thermal losses through insulation joints and thermal bridging, reduced moisture migration into the roof system and less movement in the system thereby reducing mechanical stress on the membrane. Rmax recommends two layers of insulation whenever the total insulation requirement exceeds 3.0". Joints should be offset between the insulation layers as well as between the insulation and a cover board.

**Built-Up Roof Systems (BUR)** - Specify and install Multi-Max FA-3 for use with BUR membrane systems. Secure the product to flat, smooth, dry roof decks with FM approved mechanical fasteners using one (1) fastener every four (4) square feet of insulation surface. Multi-Max FA-3 may be adhered to properly prepared concrete deck surfaces in solid flood coats of hot bitumens. Rmax recommends that when Multi-Max FA-3 is used under a BUR membrane system, it be properly protected by an overlay of mineral fiberboard, wood fiberboard, gypsum board, perlite or a venting base sheet as specified in the NRCA "Technical Bulletin #9". For additional information on attachment methods, see General under the APPLICATION / INSTALLATION section of this document.

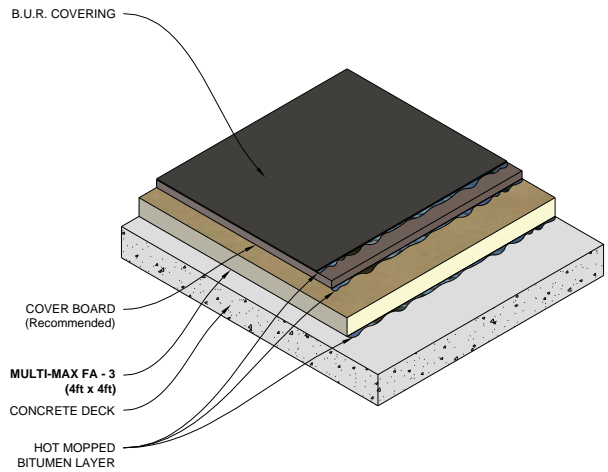

- Notes:  
 1. Vapor retarders should be applied as required and recommended by the NRCA.  
 2. Insulation and cover board may be applied using air-cured polyurethane foam as applicable.

**Modified Bitumen Systems** - Specify and install Multi-Max FA-3 for use with a modified bitumen roofing system. Rmax requires a suitable overlay of mineral fiberboard, wood fiberboard or perlite be applied to the insulation prior to application of a torch-down modified bitumen system. Rmax recommends that insulations used under hot-mopped modified bitumen membranes be protected by an overlay of mineral fiberboard, wood fiberboard, gypsum board, perlite or a venting base sheet as specified in the NRCA "Technical Bulletin #9".

Insulation shall be attached to steel decks with one (1) mechanical fastener per four (4) square feet where the insulation will be overlaid with a cover board mopped in solid flood coats of hot bitumens. Where appropriate and suitable, Multi-Max FA-3 may be adhered to properly prepared concrete roof deck surfaces in solid flood coats of hot bitumens.

For additional information on attachment methods, see General under the APPLICATION / INSTALLATION section of this document.

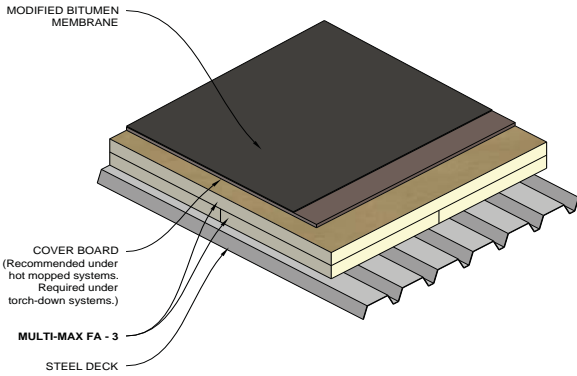

Notes:  
1. Vapor retarders should be applied as required and recommended by the NRCA.

**Fully-Adhered Single Ply Systems** - Specify and install Multi-Max FA-3 under fully-adhered single ply membranes (EPDM, PVC, TPO, etc.). Refer to the fastening diagram in this document for appropriate fastening density when using FM listed mechanical screw and plate fasteners for the attachment of Multi-Max FA-3 to steel or wood decks. Where appropriate and suitable, Multi-Max FA-3 may be adhered to properly prepared concrete roof deck surfaces in solid flood coats of hot bitumens. Follow the membrane manufacturer's recommended instructions for the type of adhesive, the application rate and proper application method for adhering the membrane to Rmax's Multi-Max FA-3. Rmax recommends the use of a suitable cover board in fully-adhered single ply membrane systems. For additional information on attachment methods, see General under the APPLICATION / INSTALLATION section of this document.

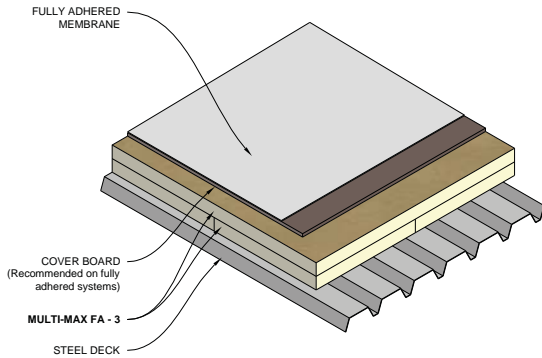

Notes:  
1. Vapor retarders should be applied as required and recommended by the NRCA.

**Mechanically Attached Single Ply Systems** - Specify and install Multi-Max FA-3 for use under all types of mechanically attached single ply membrane systems. Attach the product to the roof deck with a minimum of four (4) FM approved mechanical fasteners per four foot by eight foot (4' x 8') sheet of insulation.

NOTE: Additional fasteners in the insulation may be required by the membrane supplier. Apply the mechanically attached membrane according to membrane supplier's specifications.

**Loose Laid Ballasted Single Ply Systems** - Specify and install Multi-Max FA-3 when installing a loose laid ballasted single ply system. Multi-Max FA-3 is laid into position on the roof deck without fastening or otherwise securing the insulation. The membrane and ballast are then installed according to the membrane supplier's specifications. Ballast, placed at the specified rate, restrains the entire roof system. Please note that although fasteners are not required, fasteners may be necessary to hold the insulation system in place to stabilize insulation panels for the installation of the membrane and ballasting.

**Metal Panel Roofing Systems** - Multi-Max FA-3 may be used as the roof insulation under metal panel roof systems. Secure the product to the deck with one (1) mechanical fastener per four (4) square feet of insulation prior to attachment of the metal panel system. Attachment of the securing brackets and/or devices must be with screws of sufficient length to penetrate the insulation and engage the roofing deck and/or roof structure below by a minimum of one inch. Bearing plates and other details of construction shall be applied per the metal roofing panel manufacturer.

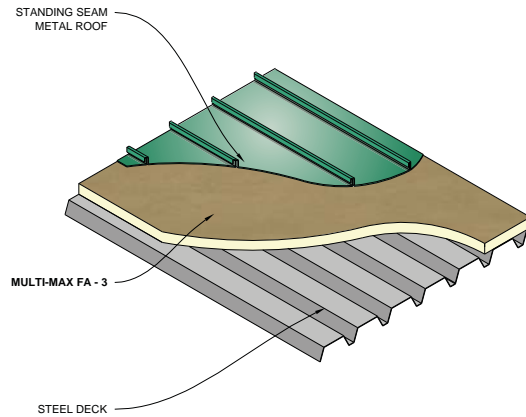

Notes:  
1. Vapor retarders should be applied as required and recommended by the NRCA.

## LIMITATIONS

Multi-Max FA-3 is not recommended nor warranted for use in inverted or protected roofing membrane systems (IRMA).

Multi-Max FA-3 is not a structural panel.

## WARNING

DO NOT leave Multi-Max FA-3 exposed. Polyiso foam is an organic material which will burn when exposed to an ignition source of sufficient heat and intensity and may contribute to flames spreading.

## WARRANTY

See Rmax "Sales Policy" for warranty conditions. Rmax does not assume any responsibility or liability for the performance of any products other than those manufactured by Rmax. **NOTE: All Rmax products must be tarped, placed on skids and kept dry before and throughout construction. Requests for Certification Letters and/or special warranty considerations must be submitted to Rmax Sales prior to delivery of the products.**

FASTENING PATTERN

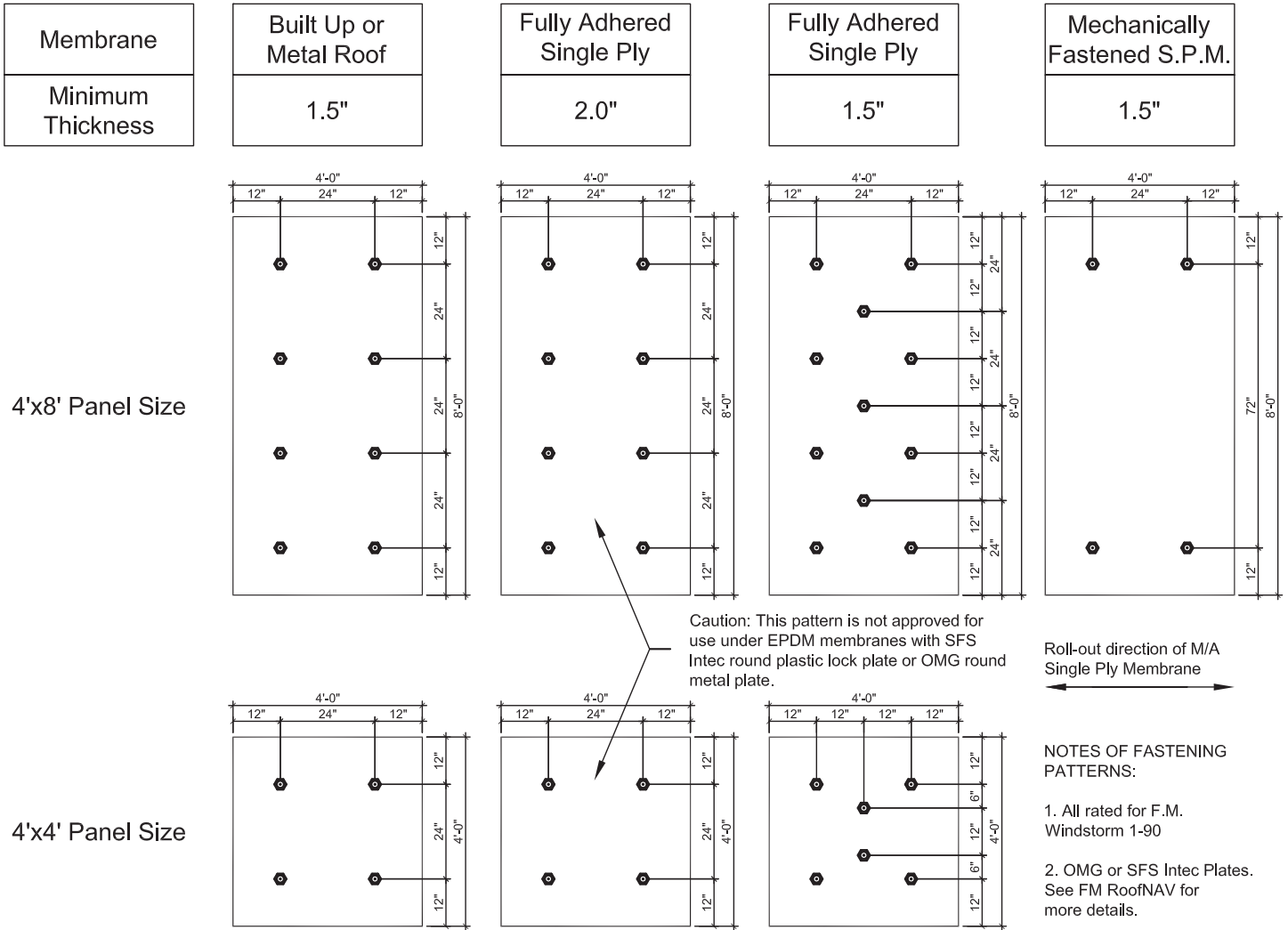

# SALES POLICY

(01-10)

## LIMITED WARRANTY

Notwithstanding anything herein to the contrary, neither Rmax Operating, LLC, nor any of its employees representatives, agents or other affiliates (collectively, "Rmax") makes any representation or warranty whatsoever, whether express or implied, concerning the Product, except that the Product was manufactured in accordance with specifications set forth in ASTM C1289, at the time of purchase is free from any lien or encumbrance, and, for a period of one (1) year from the date of delivery of the Product, is free from defects in materials and workmanship. BUYER ACKNOWLEDGES AND AGREES THAT, EXCEPT AS PROVIDED ABOVE, THE PRODUCT IS BEING DELIVERED IN AN "AS IS, WHERE IS" CONDITION, AND WITH ALL FAULTS. RMAX, HEREBY DISCLAIMS, AND BUYER HEREBY WAIVES, ANY AND ALL OBLIGATIONS AND LIABILITIES OF RMAX AND RIGHTS, CLAIMS, AND REMEDIES OF BUYER AGAINST RMAX, WHETHER EXPRESS OR IMPLIED, AND WHETHER ARISING BY LAW OR OTHERWISE, INCLUDING, WITHOUT LIMITATION, IMPLIED WARRANTIES OF MERCHANTABILITY OR FITNESS FOR A PARTICULAR PURPOSE, IMPLIED WARRANTIES ARISING FROM COURSE OF PERFORMANCE, COURSE OF DEALING, AND USAGE OF TRADE, ANY WARRANTY WITH REGARD TO ANY CLAIM OF INFRINGEMENT THAT MAY BE PROVIDED IN SECTION 2.312(3) OF THE UNIFORM COMMERCIAL CODE, AND ANY AND ALL LIABILITY WITH RESPECT TO THE PRODUCT OR SERVICES PERFORMED OR PROVIDED BY RMAX. THERE ARE NO WARRANTIES WHICH EXTEND BEYOND THE DESCRIPTION ON THE FACE HEREOF. THE WARRANTIES EXPRESSED HEREIN ARE EXCLUSIVE AND ARE GIVEN IN LIEU OF (I) ANY AND ALL OTHER WARRANTIES EXPRESS OR IMPLIED, AND (II) ANY OBLIGATION, LIABILITY, RIGHT, CLAIM OR REMEDY, IN CONTRACT, TORT OR STRICT LIABILITY, WHETHER OR NOT ARISING FROM NEGLIGENCE, ACTUAL OR IMPUTED. THE WARRANTIES EXPRESSED HEREIN SHALL BE THE EXCLUSIVE REMEDY FOR A DEFECT IN/OR DAMAGES RELATED TO THE PRODUCT.

### LIMITATION OF LIABILITY AND BUYER'S REMEDIES

IN THE EVENT OF A DEFECT IN THE PRODUCT COVERED BY THE LIMITED WARRANTY SET FORTH ABOVE, RMAX SHALL, AT RMAX'S OPTION AND EXPENSE, REPAIR OR REPLACE THE DEFECTIVE PRODUCT OR REFUND THE AMOUNT PAID BY THE BUYER FOR THE DEFECTIVE PRODUCT. THE LIABILITY OF RMAX, IF ANY, AND BUYER'S SOLE AND EXCLUSIVE REMEDY FOR DAMAGES FOR ANY CLAIM OF ANY KIND WHATSOEVER, REGARDLESS OF THE LEGAL THEORY AND WHETHER ARISING IN TORT, CONTRACT, STRICT LIABILITY OR OTHER LEGAL OR EQUITABLE THEORY, SHALL NOT BE GREATER THAN THE ACTUAL PURCHASE PRICE OF THE PRODUCT WITH RESPECT TO WHICH SUCH CLAIM IS MADE. WITHOUT LIMITATION THE FOREGOING, RMAX SHALL NOT BE LIABLE FOR BUYER'S LOSS OF USE, REVENUE OR PROFIT, OR FOR ANY OTHER DIRECT, INDIRECT, INCIDENTAL, SPECIAL, OR CONSEQUENTIAL DAMAGES OF ANY KIND (INCLUDING, WITHOUT LIMITATION, LOSS OF GOODWILL OR ANTICIPATED PROFITS OR LOST BUSINESS), AND BUYER HEREBY WAIVES ANY RIGHT IT MAY HAVE TO SUCH DAMAGES.

This LIMITED WARRANTY shall not be applicable to defects or damages which, upon inspection by Rmax, are determined by Rmax to be caused by any of the following:

- Normal wear and tear;
- Intentional vandalism or abuse, or negligent use, misuse or abuse (including any usage not in accordance with the product instructions);
- Use of parts not manufactured or sold by Rmax;
- Accident or natural disasters, including, but not limited to, fire, flood, lightning, earthquake, tornadoes, hail, hurricanes, wind storms, acts of war, acts of terrorism or acts of God; or
- Improper installation, operating, handling, storage, application or design, modification, alteration, structural movement or maintenance.

Claims against Rmax under the provisions of the LIMITED WARRANTY must be made within thirty (30) days after the alleged defect to which the claim relates is discovered or should have been discovered, by written notice to Rmax at the following address: 13524 Welch Road, Dallas, Texas, 75244; Attention – Technical Services. The written notice must be accompanied by the dated invoice or receipt received by the Buyer at the time of purchase. Rmax shall have sixty (60) days from receipt of such notice to inspect and analyze the alleged defective material. Under no circumstances shall the material to be disposed or to be returned be delivered to Rmax unless the Buyer has received written instructions to do so. Buyer shall have no right to deduct the amount of any claim from Rmax's invoice until the claim is allowed or adjusted. Failure on the part of the Buyer to follow these provisions shall waive all rights under this LIMITED WARRANTY. Unless modified in writing signed by both Rmax and Buyer, this LIMITED WARRANTY is understood to be the complete and exclusive agreement between the parties, and supersedes all prior agreements, oral or written, and all other communications between the parties relating to the subject matter of this LIMITED WARRANTY. Some states and certain federal laws do not allow limitations on how long an implied warranty lasts, so such limitations or exclusions may not apply to you. In addition, some states do not allow the exclusion or limitation of incidental or consequential damages, so such limitation or exclusion may not apply to you. This warranty gives you specific legal rights, and you may also have other rights which vary from state to state.

## GENERAL CONDITIONS

Descriptions, specifications, and recommendations described herein are subject to change without notice. Consult with Rmax Sales for the latest information. The design and construction of a roof deck and supporting structure are the responsibility of the project architect, engineer, general contractor and the building owner. The selection and use of Rmax Insulation and other roofing system components to meet the requirements for a project is at the sole discretion of the owner or his designated agent or representative.

No warranty, express or implied, as to characteristics, physical properties, or performance under any variations from controlled conditions at the time of manufacture is made. These provisions may not be altered in any way by a salesperson, employee, agent, or any other representative of Rmax, except by a letter from an officer of Rmax. Rmax does not assume any responsibility or liability for the performance of any product other than those manufactured by Rmax.

## ACCEPTANCE OF ORDERS

All orders are subject to acceptance by Rmax at its corporate office in Dallas, Texas and are not binding on Rmax unless so accepted. This acceptance constitutes a complete and binding contract which cannot be modified or canceled without written consent of both parties. The conditions stated herein shall take precedence over any other conditions, and no contrary, additional or different provisions or conditions shall be binding on Rmax unless accepted by Rmax in writing. An order has been accepted by Rmax when it has been acknowledge in writing or shipped. No order will be accepted or produced until the manufacturing plant has accumulated orders of at least 15,000 board feet of any one product in any one thickness. Orders of less than 15,000 board feet can only be accepted if the manufacturing plant can coordinate the order with another order of similar thickness.

## REVISION OF ORDERS

Change and/or cancellations of orders will be accepted providing the plant is notified five working days in advance of the requested shipping date. Notification of changes and/or cancellations must be verified in writing. On cancellations that occur after the five working day limit, the Buyer will be charged a restocking charge of 20% if the material has already been produced.

## RETURN OF ORDERS

Requests to return material to Rmax's plant must be cleared in advance by Rmax's Plant Manager. Credit for approved requests to return material, when such requests are for reasons other than material of workmanship, will be issued on the basis of the price at which the goods were originally invoiced, less the actual price of re-conditioning and restocking as determined by Rmax. Such restocking charges will be no less than 20% of the invoice price of the goods. All return freight is the Buyer's responsibility.

## TITLE-SHIPMENT-RISK OF LOSS

Title to all goods furnished under this contract of sale pass to the Buyer upon delivery by Rmax to the Carrier at Rmax's shipping point. All deliveries of goods are F.O.B. Rmax's shipping point, unless otherwise noted in the face of Rmax's quotation. Routing of shipments shall be at the sole discretion of Rmax, unless directed otherwise by the Buyer at the time of placing an order. Rmax makes every effort to deliver orders at the requested delivery time; however, Rmax does not guarantee time deliveries. A delay in delivery or shipment will not be accepted as a basis for charge-back or claim for damage. Charges for re-consignment, diversions, driver-assisted unloading, detention, and/or demurrage assessed by the Carrier in accordance with provisions of the Carrier's tariffs, will be the Buyer's responsibility. All risks of loss or damage during transit pass to the Buyer with the transfer of title as noted above. All claims for loss or damage in transit must be filed with the Carrier by the Buyer. Material is loaded in accordance with the Carrier's loading instructions to insure delivery without damage. Rmax will give all reasonable assistance to the Buyer in collecting loss or damage claims from Carrier's by furnishing duplicate invoices, affidavits showing count when loaded, method of loading, etc. Buyer should in all cases immediately report loss and/or damage to Carrier and request inspection in case of damage.

## FORCE MAJEURE

Rmax will not be liable for damages resulting from an interruption, delay, or failure to ship any order in accordance with the terms of the order where such failure is caused by any requirements of a government agency or authority, shortage of raw materials, strikes or other labor trouble, transportation delay, breakdowns, accidents, fires, riots, wars, acts of terrorism, Acts of God, or other causes beyond the control of Rmax.

## TERMS OF PAYMENT

Payment due per terms as listed on the invoice and contingent upon the Buyer having made prior satisfactory credit arrangements. Interest at the maximum rate permitted by law will be added to all invoices not paid within the stated terms as listed on the invoice.

**PRICE POLICY** - All products will be invoiced at the price in effect on the date of shipment. In the event of a price increase, all unshipped orders accepted by Rmax prior to the effective date of the price increase shall be invoiced at the increased prices in effect at the time of shipment.

**TAXES** - All applicable taxes on the production, transportation, or sale of Rmax's products shall be for the Buyer's account.

**SHIPPING AREAS** - The fifty states of the United States of America, Mexico and Canada

**SHIPPING POINTS AND MANUFACTURING PLANTS** – (1) Rmax Operating, LLC; 1649 S. Batesville Road; Greer, South Carolina 29650. (2) Rmax Operating, LLC; 13524 Welch Road; Dallas, Texas 75244. (3) Rmax Operating, LLC; 210 Lyon Drive; Fernley, Nevada 89408

**SHIPPING METHODS** - Rmax reserves the right to choose the Carrier and routing, unless otherwise directed by the Buyer in writing at the time of placing an order. Additional costs associated with Buyer specified Carriers and/or routes shall be for the Buyer's account. The standard method of shipment shall be via forty-five (45) foot, forty-eight (48) foot, or tandem flatbed trailers, where authority allows, at Rmax's option. Stopover or pooled truckloads are permitted, but limited to one stop and a final destination. The stopover location must be in line with the final destination and not in excess of 150 miles between stops. Applicable stopover charges shall be applied to the face of the invoice.

## TRUCKLOAD QUANTITIES

- 4' X 8' panels- twenty-four (24) units per forty-eight (48) foot flatbed trailer;
- 4' X 4' panels- forty-eight (48) units per forty-eight (48) foot flatbed trailer;
- Custom length panels-Orders for lengths other than those standards noted above usually cannot be accommodated on standard flatbed trailers to permit loading of the full truckload quantity required. Buyers ordering other than standard four or eight foot panels are required to order a variable item of standard length and size to fill out the load, or pay any increase in freight due to any inability to load full truckload quantity caused by nonstandard length of item(s) ordered.

**SPECIAL ORDERS** -No order will be accepted or produced until the manufacturing plant has accumulated orders of at least 15,000 board feet of any one product in any one thickness. Orders of less than 15,000 board feet can only be accepted if the manufacturing plant can coordinate the order with another order of like thickness.

**LEAD TIMES** - Lead time for the standard insulation products shall be five (5) to ten (10) working days from the receipt of the order at Rmax's manufacturing plant. Lead time for nonstandard length insulation products shall be ten (10) to twenty (20) working days from the receipt of the order at Rmax's plant. This is based upon minimum orders of 30,000 board feet. Lead time for stopover or pooled freight loads shall be as noted above except that the time shall apply only from the time that Rmax can arrange the required pool truck.

## LTL SHIPMENTS

LTL shipments are permitted subject to the following conditions:

- Minimum order is approximately 15,000 board feet.
- All LTL shipments shall be invoiced at the applicable list price plus a carton charge.
- Shipments will be freight collect with all freight charges for the Buyer's account.

**CUSTOMER PICKUP** - Customer pickup of ordered goods shall be permitted provided that the Buyer makes prior arrangement with Rmax's Plant Order Department. The Buyer shall be required to pick up goods ordered for Customer Pickup within 48 hours of notice of availability. The minimum pickup shall be ten (10) bundles.

## GENERAL PROVISIONS

This document with all attachments constitutes the entire agreement between Rmax Operating, LLC, and the Buyer and is intended as a final, complete and exclusive expression of the agreement. This agreement supersedes all prior representations, understandings and agreements. Any failure on the part of Rmax Operating, LLC to insist upon the performance of any term herein shall not be construed as a waiver or relinquishment of Rmax Operating, LLC's right to such performance and Buyer's obligation shall continue in full force and effect.

**WARNING** - Polyisocyanurate is an organic material which will burn when exposed to an ignition source of sufficient heat and intensity, and may contribute to flames spreading.

## CHOICE OF LAW

THE AGREEMENT SHALL BE GOVERNED AND CONSTRUED IN ACCORDANCE WITH THE LAWS OF THE STATE OF TEXAS, WITHOUT REGARD TO ITS CONFLICTS OF LAW OR CHOICE OF LAW PRINCIPLES.

## FORUM SELECTION CLAUSE

ANY DISPUTE ARISING OUT OF OR RELATING TO THIS TRANSACTION SHALL ONLY BE LITIGATED IN AN APPROPRIATE FEDERAL OR STATE COURT LOCATED IN DALLAS COUNTY, TEXAS

## WAIVER OF JURY

EACH PARTY HEREBY IRREVOCABLY WAIVES ANY AND ALL RIGHTS TO TRIAL BY JURY WITH RESPECT TO ANY LEGAL PROCEEDING ARISING OUT OF OR RELATING TO THIS TRANSACTION